



DAO – 2 x 9

These units, with their many unique and attractive features, provide the ultimate for those systems that require hydraulic-type (precision, smooth, and rigid) cylinder control from shop air.

Air-oil systems can provide the smoothness and rigidity of a hydraulic system without the inherent high costs and space consuming pump, motor, tank, relief valve, and other components required for a noisy hydraulic system. They may also be used as storage tanks in booster systems, see page 6.11.

Fabco-Air's unique Air-Oil tanks are available in single tank and space-saving double tank versions with bore (I.D.) sizes of 1-1/4", 2" and 4" to suit all applications.

**Single Tank Units** are used when hydraulic control of the cylinder is required in one direction only. If there is any question as to the integrity of the piston seal, a double tank is recommended.

**Single Tank Units** are also used as fluid storage tanks for boosters, hydraulic shock options, and other applications.

**Double Tank Units** are used when hydraulic control of the cylinder is required in both directions. The one-piece heads that hold both tanks simplify mounting and save space.

## Features and Benefits

- Operation to 150 psi
- Single tank units
- Double tank units, save space in two direction control systems
- Black anodized heads
- Tapped mounting holes in top and bottom heads
- Large flow ports
- Fill port on top
- Drain port on bottom
- Brass baffle plates and internal parts
- Baffles, top and bottom, help prevent fluid aeration

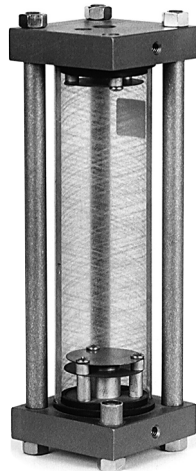

SAO – 2 x 9

- Choice of 1-1/4", 2" and 4" I.D. tanks
- Tank lengths to your requirements
- No sight tubes or gauges
- Translucent fiberglass tube provides full visibility of the fluid at all times. You can see when fluid levels are too low or too high. You can also see if there is air or foam in the fluid. (-15° to + 200°F)
- Custom molded Buna-N tube seals provide both I.D. and face sealing for a positive, no leak assembly
- Tie rods of plated, high strength threaded rod
- Aluminum tie rod cover tubes control the "H" dimension and provide controlled compression of tube seals. They also provide a clean appearance.
- Plated tie rod nuts

9

## Air-Oil System Notes

- 1 The best control is achieved by installing the speed control valves so that the fluid being forced out of the cylinder is being controlled. See the circuits on page 9.4.
- 2 The piping between the cylinder and the speed controlling valve should be rigid enough to maintain the required rigidity of the system.
- 3 It is best to mount the tanks so that the bottoms of the tanks are higher than the cylinder. Cylinder ports should be up with piping running as straight as possible to the tanks. This aids in purging the cylinder of air, by allowing the air to rise through the piping and into the tank where it will dissipate.
- 4 The highest fluid level should be kept reasonably near the top baffle to avoid excessive air usage, providing the quickest cycle reversal, and to allow for possible fluid loss.
- 5 If the fluid levels in the tanks unbalance, the fluid is bypassing the cylinder's piston seal. This can occur in a new cylinder with U-Cups designed for air service or side loading on the piston rod. In old systems the bypass can be a result of seal and cylinder wear, seal shrinkage, and many other reasons. See circuits on page 9.4 showing crossover valve for tank balancing.

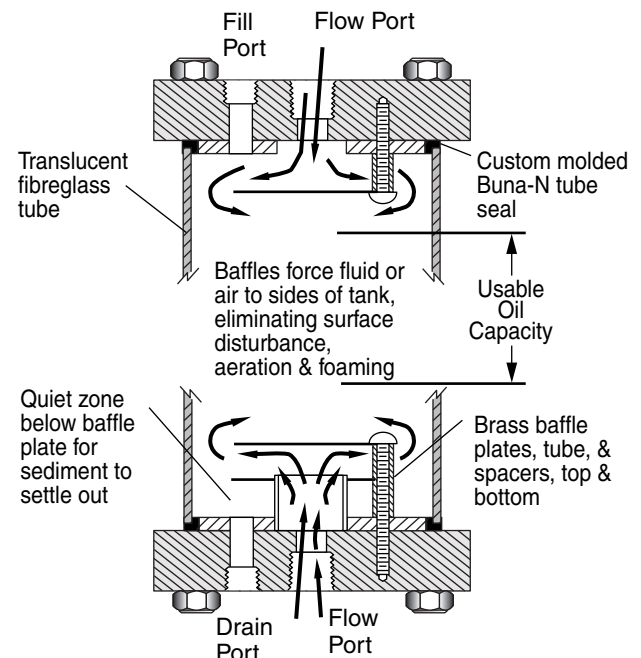

## Model Number Code

DAO - 4 x 30 - V

**Series**  
Single Tank **SAO**  
Double Tank **DAO**

**Tank Bore**  
1-1/4"  
2"  
4"

Options			Specify
Description			-V
Viton Seals (-15° to +200°F)			
Oversize Ports	Bore	Port Size	Location
	1-1/4	1/4 NPT	Top -T14
			Bottom -B14
			Both -TB14
	2	1/2 NPT	Top -T12
			Bottom -B12
			Both -TB12
	4	3/4 NPT	Top -T34
			Bottom -B34
			Both -TB34
Any port not specified will be standard size.			
Extended Tie Rods			
	Top only		
	Bottom only		
	Both		
			-WT†
			-WB†
			-WTB†
† Specify Dimension "K" in inches & fractions. See page 9.3, 1/2" increments please.			

Tank Height Inches "H"	Tank Bore Useable Oil Capacity Cubic Inches		
	4	2	1-1/4
5			1
6		3	2
7	6	6	3
8	12	8	4
9	24	11	5
10	35	13	6
11	47	15	7
12	58	18	8
13	70	20	9
14	81	23	10
15	92	25	11
16	104	27	
17	115	30	
18	127	33	
19	138	36	
20	150	39	
21	161	41	
22	173	44	
23	184	47	
24	195	50	
25	207	53	
26	218		
27	229		
28	240		
29	251		
30	263		
31	276		
32	288		
33	301		
34	314		
35	328		
36	340		
37	352		
38	364		
39	376	DAO maximum	
40	388		
41	401		
42	414		
43	427		
44	440		
45	452		
46	463		
47	477		
48	490		
49	502		
50	515		
51	527		
52	540		
53	552		
54	565		
55	578		
56	590		
57	603		
58	615		
59	628		
60	640	SAO maximum	

**Tank Height**  
**"H" Dimension**  
(See page 9.3)  
Specify in Inches as required.  
See charts at left for **"Useable Oil Capacity"** and see **"Tank Selection"** below.

### Tank Selection

**Step 1** Calculate work cylinder volume in cubic inches. Area x Stroke = Volume.

**Step 2** Add 10% to 40% to the volume for an operating margin based on system speed and level of maintenance. The higher the speed and the lower the maintenance the higher the operating margin should be.

**Step 3** From the "Usable Oil Capacity" chart, select the Bore and Height combination that provides a volume equal to, or greater than, the calculated volume with operating margin. Base your final selection on a combination of economics, available space, port size (system speed), and operating margin.

#### Example

System: 3" Bore x 6" Stroke cylinder with oil on both ends, running at low speed and well maintained.

**Step 1** Volume of 3" Bore = 7.07 sq. in. Area x 6" Stroke = 42.42 cu. in. Volume

**Step 2** 42.42 cu. in. Volume + 10% operating margin = 46.66 cu. in. with operating margin

**Step 3** Choices: DAO - 4 x 11 or DAO - 2 x 23

### How to Order

- 1 Specify the Series
- 2 Specify the Tank Bore
- 3 Specify the Tank Height, "H"
- 4 Specify Options

#### Examples

**DAO - 4 x 30 - V** Double tank, 4" bore, "H" = 30" (263 cu. in. capacity), Viton seals

**SAO - 1-1/4 x 8** Single tank, 1 1/4" bore, "H" = 8" (4 cu. in. capacity)

### Single Tank Unit, SAO

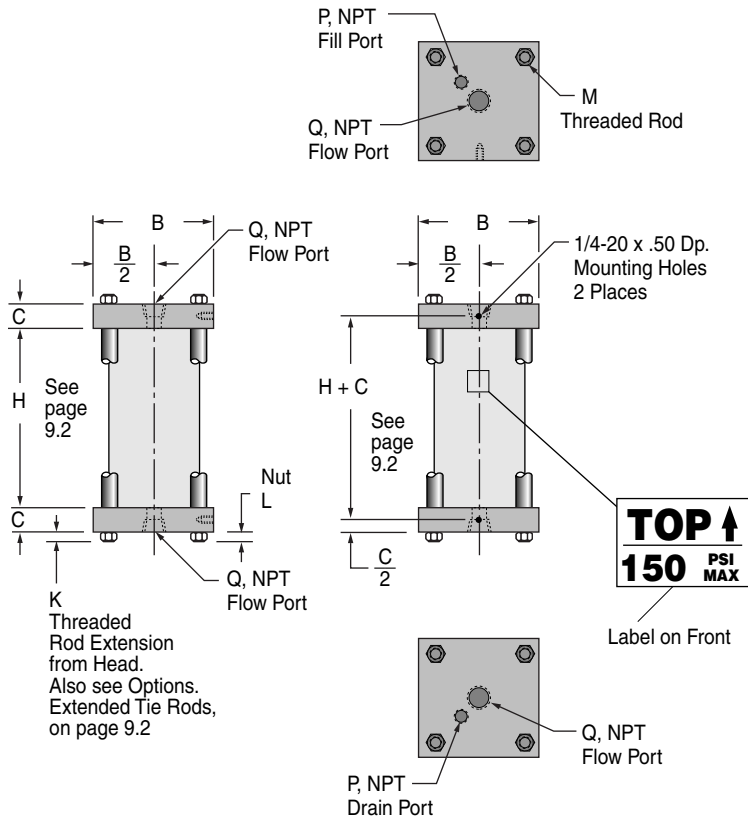

### Tie Rod Pattern

SAO -1-1/4, SAO -2, SAO -4

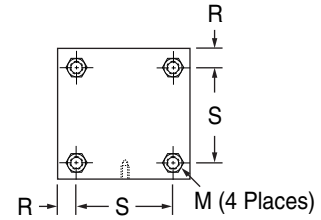

Bore	1-1/4	2	4
Vol./In.	1.22	3.14	12.56
A	4.75	7.50	10.75
B	2.00	3.00	5.25
C	0.50	0.75	1.00
E	0.38	0.50	1.88
F	4.38	7.00	8.88
G	1.31	2.13	2.63
H	See page 9.2		
J	3.44	5.38	8.13
K	0.27	0.38	0.50
L	0.22	0.33	0.43
M	1/4-20	3/8-16	1/2-13
P	1/8	1/8	1/4
Q	1/8	1/4	1/2
R	0.25	0.38	0.69
S	1.50	2.25	3.88
T	0.25	0.50	0.69
U	2.13	3.25	3.88

### 9 Double Tank Unit, DAO

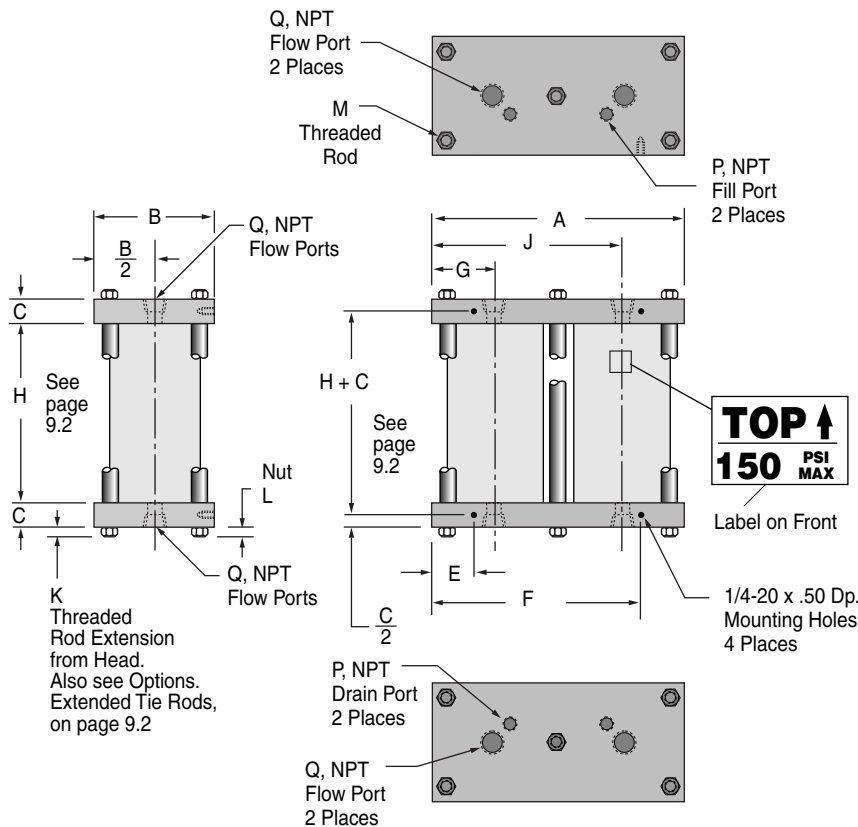

### Tie Rod Pattern

DAO -1-1/4 & DAO -2

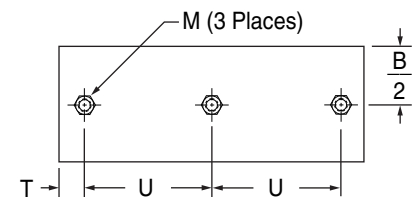

### Tie Rod Pattern

DAO -4

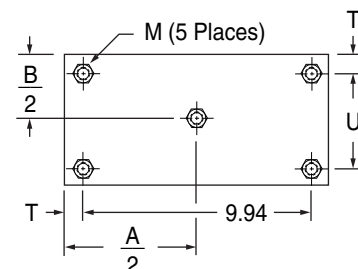

### One Speed

Single Air-Oil Tank and flow control give hydraulic control, one speed, one direction with rapid reverse.

Can be used for Multi-Power® Cylinder and Multi-Power® Air Press with Option -HS. See page 5.4 and catalog #FP-16.

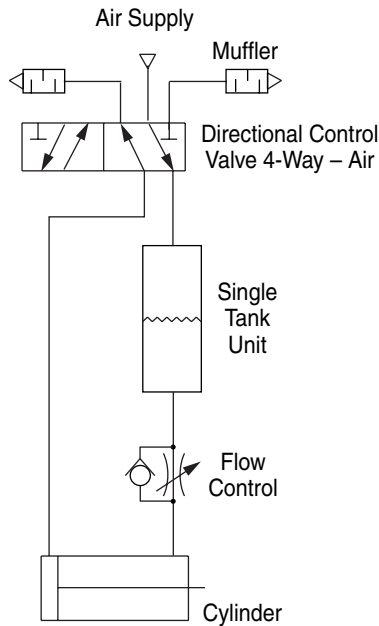

### Two Speed Stop & Hold

Double Air-Oil Tanks with shut-off valves & needle valve provide:

- ① Stop and hold in either direction at any point in cylinder travel.
- ② Choice of rapid or control rate in either direction at any point of cylinder travel.

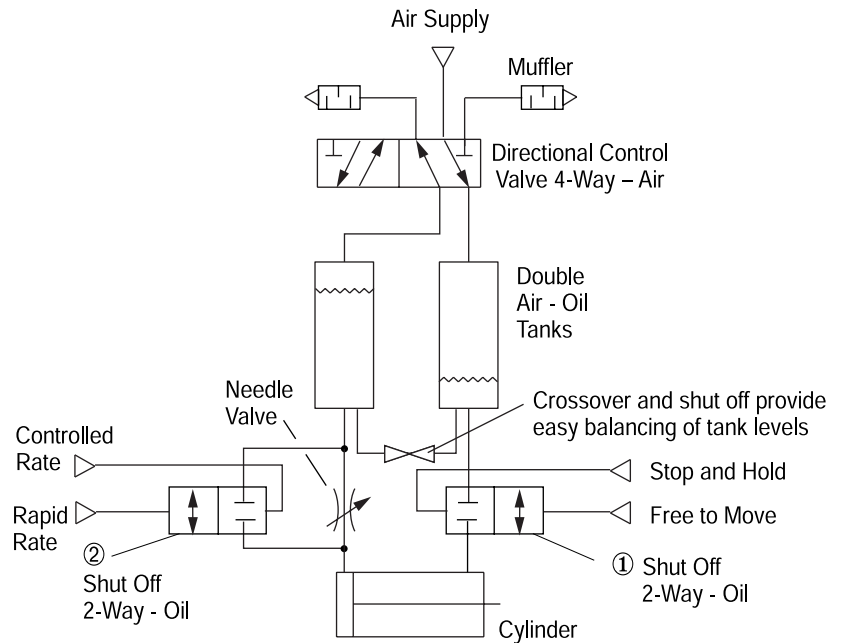

### Two Speed

Double Air-Oil Tanks and flow controls give hydraulic control, one speed, each direction.

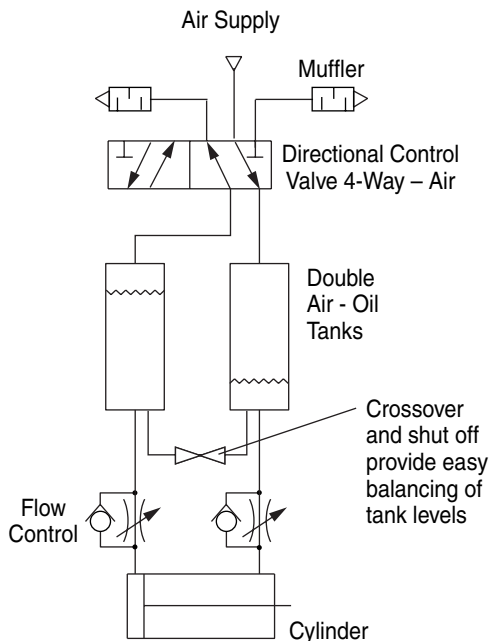

### Two Speed & Shock Control

Single Air-Oil Tank with sequence, needle and shut-off valves give:

1. Rapid extend stroke.
2. Automatic switch to controlled rate when resistance is met and pressure builds up.
3. Fluid catches cylinder when built-up forces are suddenly released (such as in a punching operation), thus controlling the shock that could otherwise occur.
4. Automatic return to rapid rate on return stroke.

**Can be used for Multi-Power® Cylinder and Multi-Power® Air Press with Option -HS. See page 5.4 and catalog #FP16.**

