

Product Index



Hi-Power™ Series –	Page
Construction & engineering data . . .	4.2 & 4.3
How to Order	4.4
Dimensions	4.5 & 4.6
Option Specifications.	4.7 - 4.10



Multi-Power® Series –	
Construction & engineering data . . .	5.1 - 5.3
Sizing Guide	5.2
How to Order	5.4
Dimensions	5.5 & 5.6
Option Specifications.	5.7 - 5.12



Pancake® Multi-Power® Series –	
Sizing Guide	5.13
How to Order	5.14
Dimensions	5.13 & 5.14



Square1® Multi-Power® Series –	
Sizing Guide	5.18
How to Order	5.18
Dimensions	5.19



Longstroke™ Multi-Power® Series –	
Sizing Guide	5.23
How to Order	5.23
Dimensions	5.24

Hi-Power™ Cylinders

Available in 3 series
10 Bore sizes 1-1/8" thru 12"
Strokes to 12"



Model THP8 x 8 - RFA shown



HP Series

- Designed for minimum overall length in relationship to stroke.
- 1/4" stroke increments to 4" maximum. For longer strokes use THP Series below.



THP Series

- Designed for minimum overall length in relationship to stroke.
- PTFE piston bearing for superior load support and longer strokes.
- 1/4" stroke increments through 4", 1" increments 5" through 12" max.

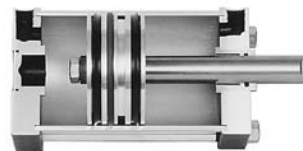

UHP Series

- Designed for minimum overall length relative to stroke.
- Buna-N U-cup seals for low break-away.
- PTFE piston bearing for superior load support and longer strokes.
- 1/4" stroke increments through 4", 1" increments 5" through 12" max.

Duralon® Rod Bearings Excel

Load Capacity (psi)		Friction Properties		
Machine Design 1972/73				
Bearing Reference Issue			Coefficient	Slip-stick
Porous Bronze.....	4,500	Steel-on-steel50	Yes
Porous iron.....	8,000	Bronze-on-steel35	Yes
Phenolics.....	6,000	Sintered Bronze-on-steel		
Nylon®	1,000	with mineral oil13	No
TFE.....	500	Bronze-on-steel		
Reinforced Telfon®	2,500	with mineral oil16	No
*TFE fabric.....	60,000	Copper lead alloy-on-steel	.22	Yes
Polycarbonate	1,000	Acetal-on-steel20	No
Acetal.....	1,000	Nylon-on-steel32	Yes
Carbon-graphite.....	600	Duralon-on-steel.....	.05 - .16	No

* Shows Duralon bearing classification. Not to be used for design purposes.

Printed with permission by Rexnord Corp.

Ratings – Standard Units all series

- Double acting, single rod
- Duralon® rod bushing
- Female rod end with wrench flats
- Internally lubricated Buna-N O-ring piston and rod seals.
- Ports at position #1
- Media Air
- Max. operating pressure 250 psi
- Min. operating pressure recommended 15 psi
- Ambient & media temperature range . . . -25° to +250°F
- Prelubrication Magnalube®-G Grease
- Stroke tolerance ± 1/64"

Sizing Guide

	1-1/8	1-5/8	2-1/2	3	4	5	6	8	10	12
Bore Diameter	1-1/8	1-5/8	2-1/2	3	4	5	6	8	10	12
Rod Diameter	0.50	0.63	0.75	0.75	1.00	1.25	1.25	1.25	2.00	2.00
Rod Area	0.20	0.31	0.44	0.44	0.79	1.23	1.23	1.23	3.1	3.1
Push Area (Single Rod)	0.99	2.07	4.91	7.07	12.57	19.63	28.27	50.27	78.5	113.0
Pull Area	0.79	1.76	4.47	6.63	11.78	18.40	27.04	49.04	75.4	109.9
HP Base Weight, lb.	0.50	1.03	2.2	2.8	5.3	8.1	10.4	N/A	N/A	N/A
THP Base Weight, lb.	0.50	1.06	2.3	2.9	5.5	8.6	11.3	19.4	61.1	82.3
UHP Base Weight, lb.	0.62	1.29	2.8	3.6	6.8	10.1	13.5	23.7	67.3	91.3
Weight Per Inch, lb.	0.13	0.20	0.4	0.4	0.6	0.7	0.8	1.7	2.6	3.4

Standard Models

HP Series

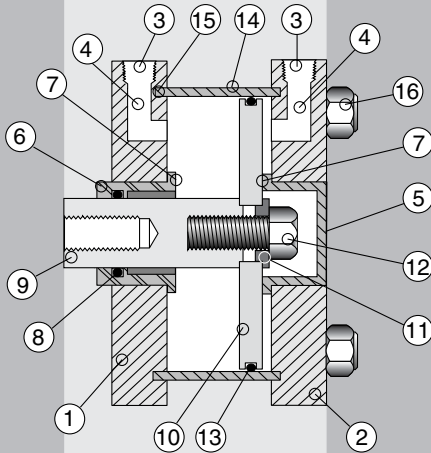

THP Series

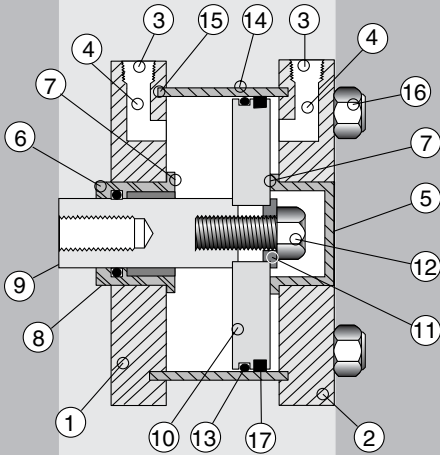

UHP Series

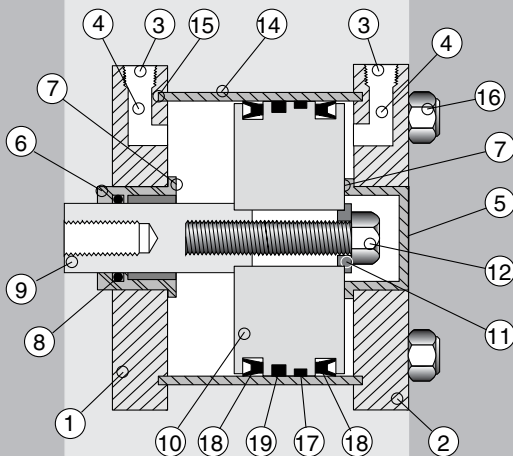

Basic Construction

Quick Reference to Components

No.	Description
1	Rod End Head, aluminum, black anodized
2	Cap End Head, aluminum, black anodized
3	NPT Ports
4	Full flow porting for fast response
5	Cap End Plug, aluminum, black anodized
6	Piston Rod Bushing, anodized aluminum housing with Teflon® lined Duralon® insert
7	Piston Stop
8	Rod Seal, internally lubricated O'Ring for long life
9	Piston Rod, stainless steel, centerless ground, polished, and hard chrome plated (68-72Rc)
10	Piston, aluminum
11	Piston Rod Pilot Washer locates piston to maintain precise concentricity
12	Piston Bolt, steel, Loctite® applied and torqued
13	Piston Seal, internally lubricated O'Ring for long life and improved performance
14	Cylinder Tube, aluminum
15	Cylinder Tube Seal
16	Stainless steel tie rods and plated steel nuts
17	PTFE Piston Bearing for superior load support
18	U Cup Seals, Buna-N
19	Magnet for piston position sensors

Cylinder OD – is clear anodized aluminum for corrosion resistance and an attractive appearance.

The Bore ID is Hard Anodized – Hard anodizing is an electrochemical process which provides a very dense surface of aluminum oxide that actually impregnates the base aluminum. It forms an extremely hard (60 Rc) surface with a low coefficient of friction. Hardness, corrosion resistance and wear resistance exceeds that of chrome plated steel.

An Extra Long Rod Bearing – provides long and rigid support for the piston rod. The bearing material is Duralon® on all bore sizes. See page 4.2 for a chart comparing the exceptional physical properties of Duralon® to other common, though less durable, bearing materials.

The Piston Rod – is Hard Chrome Plated Stainless Steel. The standard rod end is fine female thread tapped and has long wrench flats.

Piston Construction – The piston is aluminum for light weight. The piston rod pilot end and a pilot washer enable bolting the assembly securely while maintaining precise concentricity for smooth cylinder performance.

Model Number Code



Series	Bore	Standard Strokes
HP	1-1/8	1/4" Stroke Increments through 4" (maximum)
	1-5/8	
	2-1/2	
	3	
	4	
	5	
THP UHP	1-1/8	1/4" Stroke Increments through 4"
	1-5/8	
	2-1/2	
	3	
	4	1" Stroke Increments through 12" (maximum)
	5	
	6	
	8	
10		
12		

Bores	Mounting
Series HP, THP, and UHP 1-1/8" through 6"	Front Face – Fabco Pattern-FF
	Front Face – NFPA (MF1) Pattern-FFA
	Rear Face – Fabco Pattern.....-RF
	Rear Face – NFPA (MF2) Pattern.....-RFA
	Foot-FT
	Clevis Mount – NFPA (MP1) Dimensions
	Ports in-line with slot-PM
	Ports 90° to slot-SM
	Extended Tie Rods (See pg. 4.6 for non-standard lengths.)
	Rod end only-WF
Cap end only-WR	
Rod and Cap Ends.....-WFR	
Series THP and UHP only 8" 10" 12"	Front Face – NFPA (ME3) Pattern-FFA
	Rear Face – NFPA (ME4) Pattern-RFA
	Extended Tie Rods
	Rod end only-WF
Cap end only-WR	
Rod and Cap Ends.....-WFR	

How to Order

1. Specify Series and Bore
2. Specify Stroke in Inches and Fractions
3. Specify Mounting
4. Specify Options

Examples

HP3 x 3 FF – MR

HP Series Hi-Power™, 3" bore, 3" stroke, Front Face (Fabco Pattern) Mount, Male Rod Thread

THP5 x 7 – RFA – TFR

PTFE Piston Bearing Series, 5" Bore, 7" Stroke, Rear Face [NFPA MF2 pattern] Mount, 1/2 NPT Ports in Rod and Cap Heads

OPTIONS

Description	Specify	See Page
Double Rod	-DR	4.10
HP: 1-1/8" thru 6" Bore THP: 8" thru 12" Bore UHP: 1-1/8" thru 12" Bore		
Hole Thru Double Rod Shaft		4.10
150 psi max. operating pressure		
Bore Hole		
1-1/8", 1-5/8"	.13"	-DR13
2-1/2", 3"	.16"	-DR16
4", 5", 6"	.25"	-DR25
8", 10", 12"	Not available	
Nonrotating	-K	4.10
150 psi max. operating pressure		
HP: 1-5/8" Bore & Larger		
THP: All Bores		
UHP: 2-1/2" Bore & Larger		
Male Rod Thread		4.7
Single Rod	-MR	
Double Rod, Rod End	-MR	
Double Rod, Cap End	-MR1	
Double Rod, Both Ends	-MR2	
Viton Seals (-15° to +400°F)	-V	4.7
Hydraulic, Low Pressure	-H	4.10
to 500 psi NONSHOCK (HP & THP Only)		
Rubber Bumpers		4.8
Rod End	-BF	
Cap End	-BR	
Both Ends	-BFR	
Adjustable Extend Stroke	-AS	4.7
6" Stroke Maximum		
Full stroke adjustment is standard.		
1/2 NPT Ports in Heads †		4.8
(2-1/2", 3", 4", 5", & 6" Bores only)		
Rod End Head	-TF	
Cap End Head	-TR	
Both Heads	-TFR	
3/4 NPT Ports in Heads		4.8
10" & 12" Bores only		
	-P34	
Extend Port Bushing		4.8
3/8 NPT (2-1/2" – 6" Bores)	-E38	
1/2 NPT (2-1/2" – 6" Bores)	-E12	
3/4 NPT (5" – 12" Bores)	-E34	
Port Positions		4.5 & 4.6
All Ports • Position #1 Standard		
#2 -PA2; #3 -PA3; #4 -PA4		
Rod End Port •Position #1 Standard		
#2 -PR2; #3 -PR3; #4 -PR4		
Cap End Port •Position #1 Standard		
#2 -PC2; #3 -PC3; #4 -PC4		
Any port not specified will be in position #1 as shown on pages 4.5 & 4.6		
Magnetic Piston †	-E	4.9
for Reed Switches and Electronic Sensors (Order Sensors separately)		
† Note: Additional Cylinder Length Required for 1/2 NPT Ports Option see page 4.8; for Option -E see page 4.9.		

1-1/8", 1-5/8", 2-1/2", 3", 4", 5", & 6" Bores

4

-FF Front Face Mount; Rod End Rectangular Flange Fabco mounting pattern

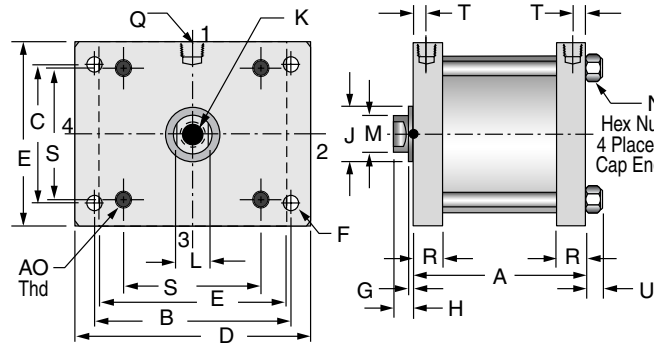

-FFA Front Face Mount; Rod End Rectangular Flange NFPA (MF1) mounting pattern

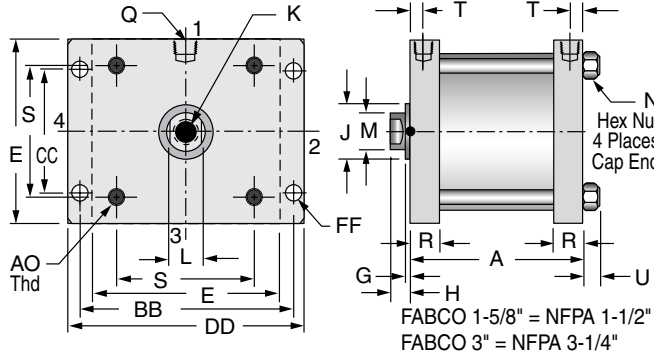

-RF Rear Face Mount; Cap End Rectangular Flange Fabco mounting pattern

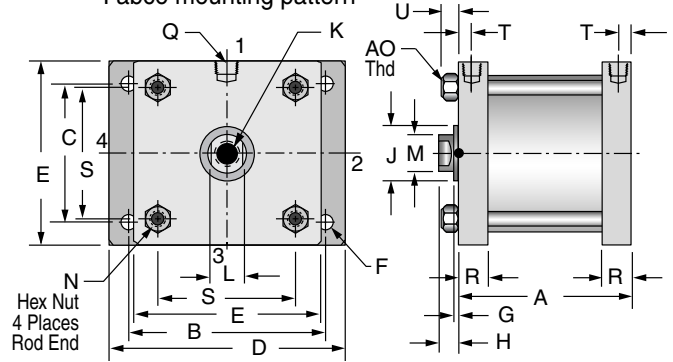

-RFA Rear Face Mount; Cap End Rectangular Flange NFPA (MF2) mounting pattern

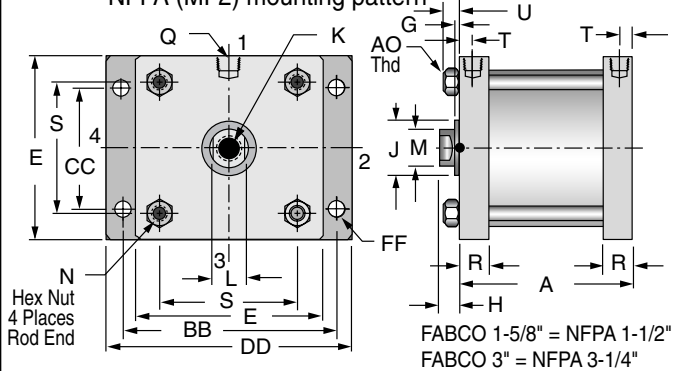

Clevis Mount (NFPA MP1 Dimensions)

- PM** - Ports in-line with slot
- SM** - Ports 90° to slot

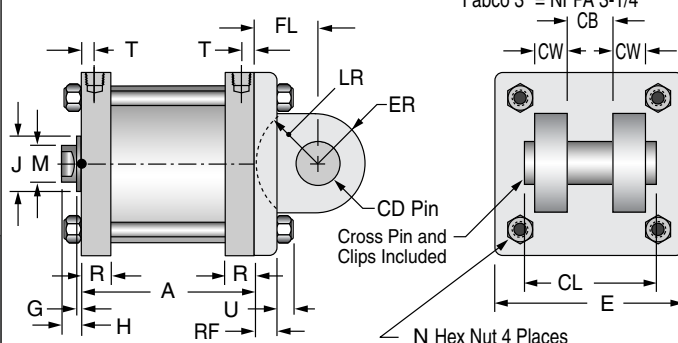

Material: Gray Iron Casting,
Black Oxide Finish

Dimensions (inches)

Bore	A			B	C	D	E	F	G	H	J ±.002	K	L	M ±.001	N	P	Q NPT	R
	Series HP	Series THP	Series UHP															
1-1/8	1.31 + stroke	1.50+stroke	2.63+stroke	2.00	1.25	2.50	1.75	.28	.13	.50	.752	5/16-24x.63	7/16	.500	7/16	2.38	1/8	.50
1-5/8	1.75 + stroke	2.00+stroke	3.00+stroke	2.50	1.75	3.00	2.25	.28	.13	.50	1.001	3/8-24x.63	1/2	.625	7/16	2.88	1/8	.63
2-1/2	2.06 + stroke	2.25+stroke	3.25+stroke	3.63	2.38	4.25	3.00	.34	.19	.50	1.127	1/2-20x.75	5/8	.750	9/16	3.69	1/4	.75
3	2.06 + stroke	2.25+stroke	3.25+stroke	3.88	2.75	4.50	3.50	.34	.19	.50	1.127	1/2-20x.75	5/8	.750	9/16	4.13	1/4	.75
4	2.06 + stroke	2.25+stroke	3.25+stroke	5.00	3.75	6.00	5.00	.41	.19	.50	1.502	1/2-20x.75	7/8	1.000	3/4	5.50	1/4	.75
5	2.50 + stroke	2.75+stroke	3.50+stroke	6.00	4.50	7.00	6.00	.53	.19	.69	1.752	3/4-16x1.13	1	1.250	3/4	6.25	1/4	.75
6	2.38 + stroke	2.75+stroke	3.50+stroke	7.00	5.25	8.00	7.00	.53	.19	.69	1.752	3/4-16x1.13	1	1.250	3/4	3.38	1/4	.75
8	NA	2.88+stroke	3.75+stroke	7.57	NA	NA	9.00	.69	.13	.63	1.752	3/4-16x1.13	1	1.250	3/4	NA	3/8	1.00
10	NA	4.75+stroke	5.75+stroke	9.40	NA	NA	12.00	.78	.25	1.00	2.751	1 1/2-12x1.75	1.75	2.000	1-1/8	NA	1/2	1.50
12	NA	4.75+stroke	5.75+stroke	11.10	NA	NA	14.00	.78	.25	1.00	2.751	1 1/2-12x1.75	1.75	2.000	1-1/8	NA	1/2	1.50

VITON SEALS

OPTION -V

Use for elevated temperatures (-15° to + 400°F) or compatibility with exotic media. Consult engineering for compatibility information.

MALE ROD THREAD

- Single Rod **-MR**
- Double Rod, Rod End Only **-MR**
- Double Rod, Cap End Only **-MR1**
- Double Rod, Rod & Cap Ends **-MR2**

For bores 1-1/8" thru 8", a high strength stud is threaded into the standard female rod end and retained with Loctite®. This method eliminates the small diameter thread relief area normally required when machining male

threads. This provides a much stronger rod end which can be repaired, rather than replacing the complete rod, should the thread be damaged. For 10" and 12", the thread is machined integral with the rod.

4

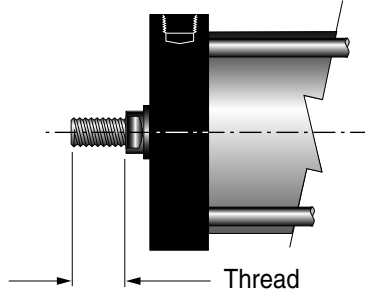
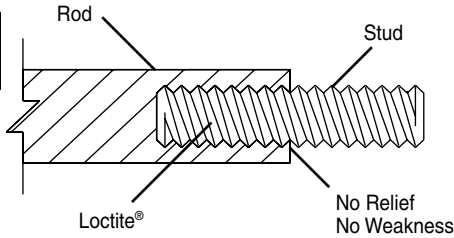

BORE	THREAD
1-1/8"	.5/16-24 x .63
1-5/8"	3/8-24 x .88
2-1/2"	1/2-20 x 1.00
3"	1/2-20 x 1.00
4"	1/2-20 x 1.00
5"	3/4-16 x 1.50
6"	3/4-16 x 1.50
8"	3/4-16 x 1.50
10"	1-1/2-12 x 2.25
12"	1-1/2-12 x 2.25

ADJUSTABLE EXTEND STROKE

For strokes through 6" **-AS**
Full stroke adjustment is standard.

Note!

To maintain operator safety features of this option, it is **NOT** available with mounting styles: -WR and -WFR. Use caution when mounting to avoid creating pinch points.

Not available for 10" & 12" bores

Dial-A-Stroke® provides a rugged and precision adjustment of the extend stroke of the cylinder. The stop tube, adjustment nut with skirt, and minimum clearances combine to eliminate pinch points, thus providing operator safety. **Note!** Use caution when mounting to avoid creating pinch points with other parts of your machine design.

The stop tube is blue anodized aluminum, the adjustment nut is blackened steel with a black anodized aluminum skirt, and the nut stop is red anodized aluminum; all for corrosion resistance and appearance. The adjustment nut, steel for long life, includes a lock screw with a plastic plug so that the adjustment nut can be locked in place without damaging the threads. The nut stop is mounted on the end of the adjustment rod so that the nut cannot come off. The fine pitch threads on the adjustment rod and nut provide precision adjustment. (See dimension "BF"). Adjustment settings are simplified by convenient scale markings applied to nut skirt and stop tube.

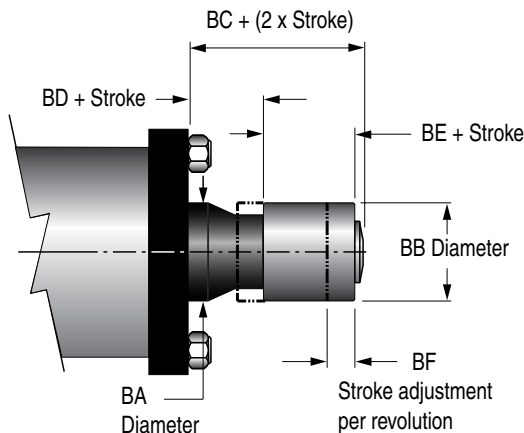
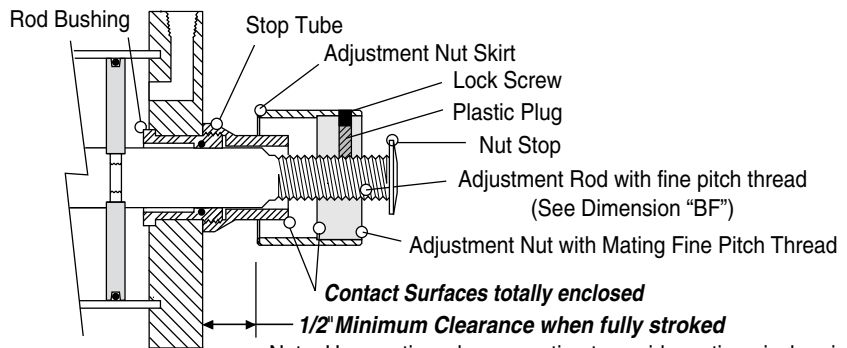

Bore	1-1/8"	1-5/8"	2-1/2"	3"	4"	5"	6"	8"	
BA	1.13	1.25	1.50	1.50	2.00	2.25	2.25	2.25	
BB	1.50	1.50	2.00	2.00	2.00	2.25	2.25	2.25	
BC	1.67	1.67	1.90	1.90	1.67	1.67	1.67	1.67	+ (2 x Stroke)
BD	1.00	1.00	1.00	1.00	.75	.75	.75	.75	+ Stroke
BE	.50	.50	.75	.75	.75	.75	.75	.75	
BF	.050	.050	.063	.063	.063	.071	.071	.071	

EXTEND PORT BUSHING OPTION
 3/8 NPT (2-1/2" – 8" bores) **-E38**
 1/2 NPT (2-1/2" – 8" bores) **-E12**
 3/4 NPT (5" – 12" bores) **-E34**

The cap end plug is replaced with an extended plug of black anodized aluminum with a female NPT port. The standard cap end port is plugged.

Use for plumbing convenience, or when higher air flows are required for higher cycle speeds.

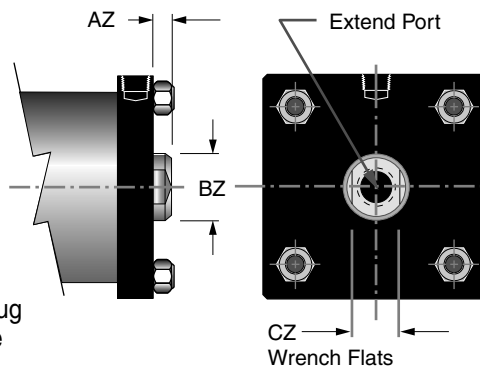
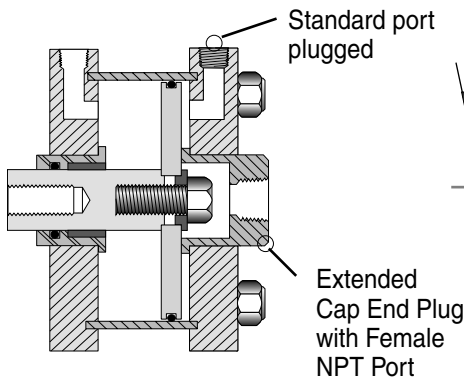

Dimensions (inches)						
Bore	AZ	BZ	CZ	Availability		
				E38	E12	E34
2-1/2	.38	1.13	.94	✓	✓	-
3	.38	1.13	.94	✓	✓	-
4	.38	1.50	1.26	✓	✓	-
5	.38	1.75	1.50	✓	✓	✓
6	.38	1.75	1.50	✓	✓	✓
8	.31	1.75	1.50	✓	✓	✓
10	.50	2.75	2.25	-	-	✓
12	.50	2.75	2.25	-	-	✓

4

1/2 NPT PORTS IN HEADS

2-1/2", 3", 4", 5", & 6" Bores only

Rod End Head **-TF**
 Cap End Head **-TR**
 Both Heads **-TFR**

3/4 NPT PORTS IN BOTH HEADS

10" & 12" Bores only

-P34

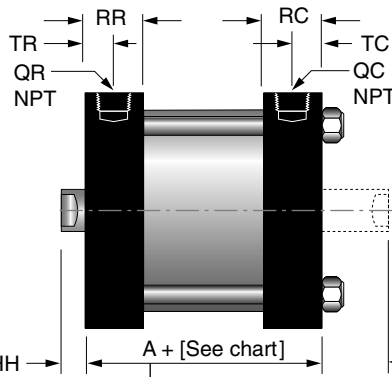
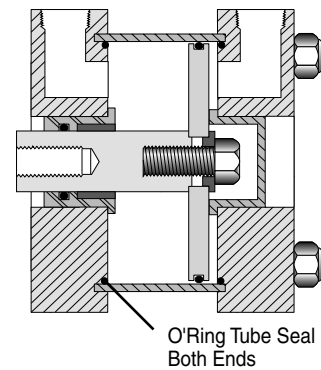

For 2-1/2" thru 6" bores thicker heads (to accept 1/2 NPT ports) replace the standard heads. Because of the thicker heads, there is an increase in the Dimension "A" and a reduction of the rod extension as charted below. With this construction, an O'Ring replaces the fiber gasket cylinder tube seal.

For 10" and 12" bores, 3/4 NPT ports are applied to standard heads.

Use when higher cycle speeds are required.

See pages 4.5 & 4.6 for Dimension "A"

Option	Add to A	QC	QR	RC			RR			HH	HH	HH	HH-DR	HH-DR	HH-DR	TC	TR
				2-1/2 & 3" Bore	4, 5 & 6" Bore	10 & 12" Bore	2-1/2 & 3" Bore	4, 5 & 6" Bore	10 & 12" Bore								
TF	.38	1/4	1/2	0.75	0.75	-	1.00	1.25	-	0.12	0.31	-	0.50	0.69	-	.31	.50
TR	.38	1/2	1/4	1.00	1.25	-	0.75	0.75	-	0.50	0.69	-	0.12	0.31	-	.50	.31
TFR	.76	1/2	1/2	1.00	1.25	-	1.00	1.25	-	0.12	0.31	-	0.12	0.31	-	.50	.50
P34	0.00	3/4	3/4	-	-	1.50	-	-	1.50	-	-	1.00	-	-	1.00	.63	.63

RUBBER BUMPERS

Rod End only **-BF**
 Cap End only **-BR**
 Both Rod & Cap Ends **-BFR**

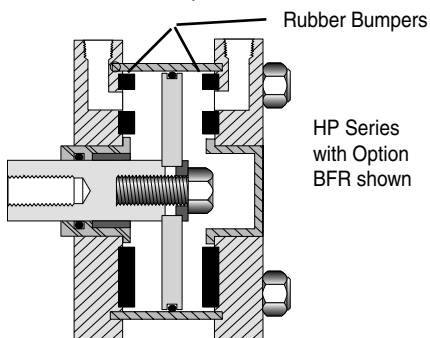

A rubber doughnut is bonded to the cylinder head to act as the piston stop and absorb the impact of the piston. This reduces noise and absorbs energy, thus reducing damage to the cylinder and tooling due to pounding. The amount of rubber that extends beyond the normal piston stop is designed to compress and allow full stroke of the cylinder at 60 to 80 psi. If your application uses lower pressure or has high energy, consult engineering with application details so that rubber mass can be adjusted to meet your specific requirements.

Because of the temperature limitations of the adhesives involved (-25° to +225°F), rubber bumpers are available in cylinders with standard internally lubricated Buna-N seals only.

Use where noise reduction and impact absorption is desired.

Note! On applications such as punching, shearing, setting blind rivets, etc., where high forces are built up and then released VERY quickly, the proper method of "catching" this type of load is to adjust the cylinder piston and the tooling so that at the point of breakthrough the piston is very close to the bumper. This reduces the dynamic load that the piston and bumper are required to absorb.

Standard rubber mass will compress and give full stroke at 60 to 80 psi. This mass can be adjusted to meet your specific pressure and/or dynamic load requirements.

MAGNETIC PISTON

Option -E



Order Sensors and Sensor Clamps Separately

- **Option -E** consists of a magnet bonded into the piston head. When the piston magnet moves past an external sensor, the magnetic field activates the sensor without physical contact.
- **Mounting** – The sensor is attached to a 2-part clamp that attaches rigidly to a tie rod and can be positioned anywhere along the length of the cylinder for very precise signaling.
- Two sensor styles are used – (a) the **9-2A197 Series** for 1-1/8" thru 3" bores requires a tie rod clamp, and (b) the **749 Series** which accommodates the larger diameter tie rods of the 4" thru 12" bores with an integral clamp.
- **Reliability** – The annular piston magnet is permanently bonded into a groove in the piston. It is a polarized permanent magnet of rubber bonded barium ferrite that is very stable and is not affected by shock. Under normal usage it will remain magnetized indefinitely.
- **Warning** – External magnetic fields and/or ferrous objects may affect the strength of the piston magnet therefore affecting sensor actuation and piston position indication. Labels noting this are affixed to the cylinder.
- **Please note there is an increase in base length of the cylinder to accommodate the magnet. Using the table below add 'L' to Dimension 'A' on pages 4.5 & 4.6.**

4

9-2A197 Series Sensor & Clamp for 1-1/8" to 3" Bores

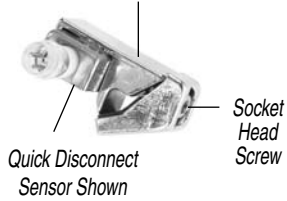

749 Series Sensor with Integral Clamp for 4" to 12" Bore Cylinders (shown prewired)

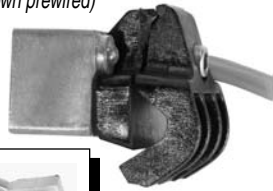

(T) Clamp Stick Out & (L) Length Adder to Dim. 'A' Pgs. 4.5 & 4.6

Bore	1-1/8"	1-5/8"	2-1/2"	3"	4"	5"	6"	8"	10"	12"
T	.38	.38	.38	.38	.36	.25	.14	.10	.38	.38
L (for Series HP)	1	1	1	1	1	1	1"	NA	NA	NA
L (for Series THP)	.81	.75	.81	.81	.81	.75	.63	1.25	1.00	1.00
L (for Series UHP)	0	0	0	0	0	0	0	0	0	0

WARNING
This cylinder is equipped with a Magnetic Piston for use with Magnetically Operated Sensors. Other Magnetic Sensitive Devices Should be Kept at a Distance to Avoid Inadvertent Operation.

1-1/8" – 3" Bores

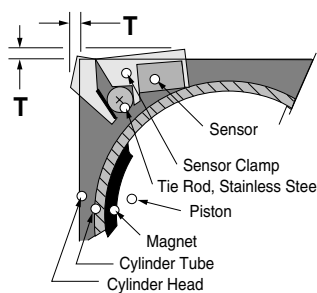

4" – 6" Bores

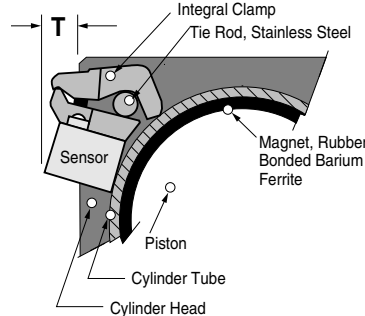

8", 10" & 12" Bores

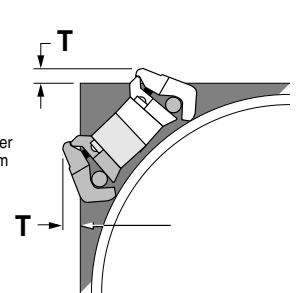

Sensor & Clamp Ordering Guide

Temperature Range: -20° to + 80°C (-4° to + 176°F)

Warning! Do not exceed sensor ratings. Permanent damage to sensor may occur. Power supply polarity **MUST** be observed for proper operation of sensors. See wiring diagrams included with each sensor.

LED Lighted Magnetic Piston Position Sensors: Bores 1-1/8" – 3"			
Product	9 ft. Prewired P/N	Quick Discon. P/N	Electrical Characteristics
Reed Switch	9-2A197-1004	9-2A197-1304	5-120 VDC/VAC, 0.5 Amp Max., 10 Watt Max., SPST N.O., 3.5 Voltage Drop
Electronic	9-2A197-1033	9-2A197-1333	Sourcing, PNP, 6-24 VDC, 0.5Amp Max., 1.0 Voltage Drop
Electronic	9-2A197-1034	9-2A197-1334	Sinking, NPN, 6-24VDC, 0.5Amp Max., 1.0 Voltage Drop
9-2A197 Series Sensor Mounting Clamps – Part Number 800-200-000			
LED Lighted Magnetic Piston Position Sensors: Bores 4" – 8"			
Product	9 ft. Prewired P/N	Quick Discon. P/N	Electrical Characteristics
Reed Switch	749-000-004	749-000-504	5-240 VDC/VAC, 1 Amp Max., 30 Watt Max., SPST N.O., 3.0 Voltage Drop
Electronic	749-000-031	749-000-531	Sourcing, PNP, 6-24 VDC, 1.0 Amp Max., 0.5 Voltage Drop
Electronic	749-000-032	749-000-532	Sinking, NPN, 6-24 VDC, 1.0 Amp Max., 0.5 Voltage Drop
LED Lighted Magnetic Piston Position Sensors: Bores 10" & 12"			
Product	9 ft. Prewired P/N	Quick Discon. P/N	Electrical Characteristics
Reed Switch	749-111-004	749-111-504	5-240 VDC/VAC, 1 Amp Max., 30 Watt Max., SPST N.O., 3.0 Voltage Drop
Electronic	749-111-031	749-111-531	Sourcing, PNP, 6-24 VDC, 1.0 Amp Max., 0.5 Voltage Drop
Electronic	749-111-032	749-111-532	Sinking, NPN, 6-24 VDC, 1.0 Amp Max., 0.5 Voltage Drop

Female Cordsets for 9-2A197 Series Quick Disconnect Sensors			
Length	1 Meter	2 Meter	5 Meter
Part No.	CFC-1M	CFC-2M	CFC-5M
Female Cordsets for 749 Series Quick Disconnect Sensors			
Length	2 Meter		5 Meter
Part No.	CFC-2M-12		CFC-5M-12

Double Rod -DR

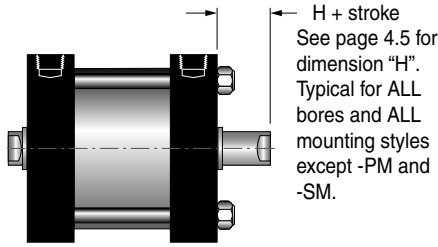

Standard piston rod and rod bushing on both ends of the cylinder.

Available in Series HP – 1-1/8" thru 6" bore; THP – 8" thru 12" bore; and UHP – 1-1/8" thru 12" bore, with 1/4" inch stroke increments through 4" and 1" stroke increments to 12". The THP

Series (PTFE piston bearing) is not required because the two rod bushings provide excellent piston support.

Use when attachment to both ends of the cylinder is required, or to indicate piston position. Also see Option –E on page 4.9.

Hole Thru (4" stroke maximum) 150 psi max. operating pressure

Bore	Hole Size	Option
1-1/8", 1-5/8"	.13"	-DR13
2-1/2", 3"	.16"	-DR16
4", 5", 6", 8", 10", 12"	.25"	-DR25
	Not available	

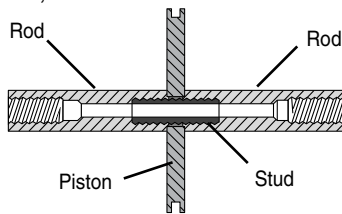

A hole is drilled through the piston rods and the double rod stud. The rods are centered by pilot bosses in the piston and threaded tightly on the hollow stud.

This hole can be used for the passage of air, gas, liquid, or any media that is compatible with the stainless steel piston rod and the steel stud.

The hole for each bore size is shown in the chart at the left.

Available in Series HP and UHP only with 1/4" stroke increments through a maximum of 4".

Use when the attachment to the rod required a fluid or vacuum.

Nonrotating Rod -K 150 psi max. operating pressure

HP 1-5/8" Bore and larger
THP All Bores
UHP 2-1/2" Bore and larger

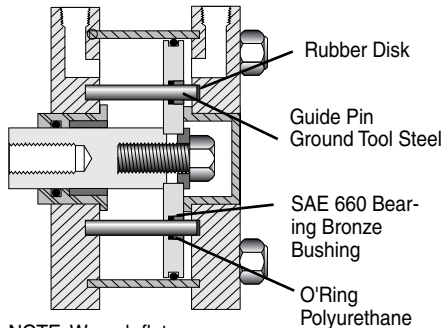

NOTE: Wrench flats have random location

Two guide pins incorporated inside the cylinder pass through the piston head. These guide pins prevent rotation of the rod with a tolerance of $\pm 1^\circ$.

Note that the nonrotating guide pins are located internally. This provides protection from the environment and from physical damage, common lubrication with the cylinder, and NO additional space requirements. The rod end area is free for any attachments or tooling required by your application.

The guide pins are precision ground tool steel and run in SAE 660 bearing bronze bushings and polyurethane

O'Rings. These features provide precision guiding and long, trouble free life. A rubber disk is included at the end of each guide pin to take up end play and seat the pins firmly in the guide pin holes.

An information label similar to the one below is applied to each cylinder to warn against damage.

WARNING

THIS CYLINDER HAS A NONROTATING ROD. TO PREVENT INTERNAL DAMAGE, HOLD ROD BY WRENCH FLATS WHEN INSTALLING OR REMOVING ATTACHMENTS.

Hydraulic -H Low pressure service to 500 psi **Nonshock**

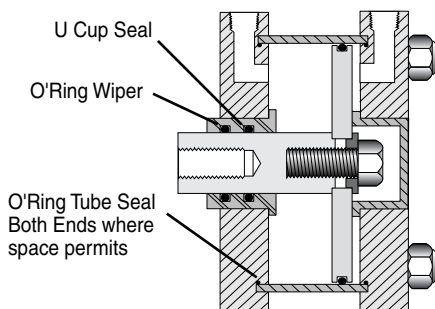

Where space permits, a U Cup seal is placed inboard in an SAE 660 bronze bushing to eliminate leakage past the rod seal; an O'Ring is used as an outboard wiper.

When space is limited, two O'Ring seals are used in the bronze bushing.

Note: -PM or -SM mounts are NOT available for applications over 250 psi.

Use with an Air-over-Oil system when the rigidity and precision smoothness of hydraulics and control is required. See page 5.11 and section 9 of this catalog for information on Air Oil Tanks and systems.